

K1 64 AND K1 72 ENGINES

*Power ranges: 2.1 - 6.3 kW; 2.8 - 8.4 bhp
Variable or fixed speed; full load speed range: 2000—3600 r/min*

CLEAN, RELIABLE AND DURABLE AIR COOLED DIESEL ENGINES

SPECIAL ATTRIBUTES

- variable and fixed speed builds available
- 100-hour service intervals
- designed for continuous operation in ambient temperatures up to 40°C (104°F)

BASIC ENGINE CHARACTERISTICS

- diesel fuelled
- direct injection
- single cylinder
- vertical
- 4-stroke
- naturally aspirated
- air cooled

DESIGN FEATURES AND EQUIPMENT

- power take off, crankshaft or camshaft (camshaft PTO is half speed)
- air cleaner (type according to application)
- inlet manifold
- engine mounted exhaust silencer
- recoil or recoil/electric starting
- decompressor lever
- fuel tank with integral fuel filter



**K1 72 SHOWN WITH OPTIONAL
HEAVY DUTY AIR CLEANER**

- gear-driven lubricating oil pump
- balancer shaft
- washable oil filter
- operators' handbook

EMISSIONS

- emission compliant to EPA Interim T4 3600r/min engines only

3600 r/min VARIABLE SPEED: POWER OUTPUTS TO ISO 3046¹										
Model	Power	r/min:	2200	2400	2600	2800	3000	3200	3400	3600
K1 64	Continuous	kW	2.2	2.4	2.6	2.8	3.1	3.3	3.4	3.6
		bhp	3.0	3.2	3.5	3.8	4.1	4.4	4.6	4.8
	Fuel Stop	kW	2.4	2.6	2.9	3.1	3.4	3.6	3.8	4.0
		bhp	3.2	3.5	3.9	4.2	4.6	4.8	5.1	5.4
K1 72	Continuous	kW	3.4	3.7	4.1	4.5	4.9	5.2	5.5	5.7
		bhp	4.6	5.0	5.5	6.1	6.6	7.0	7.4	7.6
	Fuel Stop	kW	3.8	4.1	4.5	5.0	5.4	5.7	6.0	6.3
		bhp	5.1	5.5	6.1	6.7	7.2	7.6	8.1	8.4

3000 r/min VARIABLE SPEED: POWER OUTPUTS TO ISO 3046¹									
Model	Power	r/min:	2000	2200	2400	2600	2800	3000	
K1 64	Continuous	kW	2.1	2.4	2.6	2.9	3.1	3.3	
		bhp	2.8	3.2	3.5	3.9	4.1	4.4	
	Fuel Stop	kW	2.3	2.6	2.8	3.2	3.4	3.7	
		bhp	3.1	3.5	3.8	4.3	4.6	5.0	
K1 72	Continuous	kW	3.2	3.6	4.0	4.5	4.8	5.2	
		bhp	4.3	4.8	5.4	6.0	6.4	7.0	
	Fuel Stop	kW	3.5	3.9	4.4	4.9	5.4	5.7	
		bhp	4.7	5.3	5.9	6.6	7.2	7.6	

FIXED SPEED: POWER OUTPUTS TO ISO 3046¹				
Model	Power	r/min	3000	3600
K1 64	Continuous	kW	3.3	3.6
		bhp	4.4	4.8
	Fuel Stop	kW	3.6	4.0
		bhp	4.8	5.3
K1 72	Continuous	kW	5.2	5.7
		bhp	7.0	7.6
	Fuel Stop	kW	5.7	6.3
		bhp	7.6	8.4

Key to Emissions Compliance

USA EPA Interim Tier 4 only	
-----------------------------	--

1. Power ratings measured at the flywheel and fuel consumptions, apply to a fully run-in, non derated engine without power absorbing accessories or transmission equipment. For rating definitions see page 3.
2. The overload capability applies to a fully run-in engine. This is normally attained after a running period of about 50 hours.

3600 r/min VARIABLE SPEED: TORQUE										
Model	Power	r/min:	2200	2400	2600	2800	3000	3200	3400	3600
K1 64	Fuel Stop	Nm	10.6	10.7	10.7	10.7	10.8	10.7	10.7	10.6
		lbf ft	7.8	7.8	7.8	7.9	7.9	7.9	7.9	7.8
K1 72		Nm	16.5	16.5	16.7	17.1	17.2	17.2	17.0	16.7
		lbf ft	12.2	12.2	12.3	12.5	12.7	12.6	12.5	12.3

3600 r/min VARIABLE SPEED: MAXIMUM FUEL CONSUMPTION

The figures given are for 100% load and are subject to 5% tolerance.

Model	Power	r/min	2200	2400	2600	2800	3000	3200	3400	3600
K1 64	Continuous	litre/hr	0.7	0.8	0.8	0.9	1.0	1.1	1.2	1.3
		US gal/hr	0.19	0.21	0.23	0.25	0.27	0.29	0.33	0.35
K1 72		litre/hr	1.1	1.2	1.3	1.5	1.6	1.8	1.95	2.1
		US gal/hr	0.29	0.32	0.35	0.39	0.43	0.47	0.51	0.56

3000 r/min VARIABLE SPEED: TORQUE

Model	Power	r/min:	2000	2200	2400	2600	2800	3000
K1 64	Fuel Stop	Nm	11.1	11.3	11.3	11.8	11.8	11.7
		lbf ft	8.2	8.3	8.3	8.7	8.7	8.6
K1 72		Nm	16.7	17.2	17.5	18.4	18.2	18.1
		lbf ft	12.3	12.6	12.9	13.5	13.4	13.3

3000 r/min VARIABLE SPEED: MAXIMUM FUEL CONSUMPTION

The figures given are for 100% load and are subject to 5% tolerance.

Model	Power	r/min	2000	2200	2400	2600	2800	3000
K1 64	Continuous	litre/hr	0.7	0.7	0.8	0.9	1.0	1.1
		US gal/hr	0.2	0.2	0.22	0.25	0.27	0.29
K1 72		litre/hr	1.0	1.1	1.3	1.5	1.6	1.7
		US gal/hr	0.27	0.30	0.34	0.39	0.42	0.45

TECHNICAL DATA

		K1 64	K1 72
Type of fuel injection		Direct	Direct
Number of cylinders		1	1
Aspiration		Natural	Natural
Direction of rotation (gear end)		Anti clockwise	Anti clockwise
Nominal cylinder bore	mm	78	86
	in	3.07	3.38
Stroke	mm	64	72
	in	2.52	2.83
Total cylinder capacity	litre	0.305	0.418
Total cylinder capacity	in ³	18.61	25.51
Compression ratio		19:1	19:1
Minimum idling speed	r/min	1300	1300
Minimum full load speed	r/min	2200	2200

ENGINE PRODUCT CODES AND SHAFT TYPES

PRODUCT CODE INFORMATION

K164PCEHS30VS

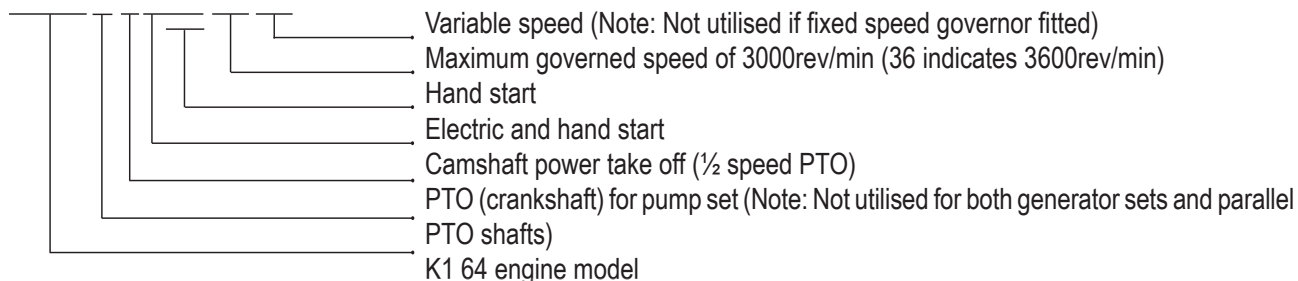

FIXED SPEED APPLICATIONS - GENERATOR SETS				
Shaft type*	K Series - Hand Start		Fixed Speed - Continuous	
	Engine Model	Product code	rpm	kW
1	K1 64	K1 64HS30	3000	3.3
		K1 64HS36	3600	3.6
1A	K1 72	K1 72HS30	3000	5.2
		K1 72HS36	3600	5.7

Shaft type*	K Series - Electric Start		Fixed Speed - Continuous	
	Engine Model	Product code	rpm	kW
1	K1 64	K1 64ES30	3000	3.3
		K1 64ES36	3600	3.6
1A	K1 72	K1 72ES30	3000	5.2
		K1 72ES36	3600	5.7

Shaft type*	K Series - Hand & Electric Start		Fixed Speed - Continuous	
	Engine Model	Product code	rpm	kW
1	K1 64	K1 64EHS30	3000	3.3
		K1 64EHS36	3600	3.6
1A	K1 72	K1 72EHS30	3000	5.2
		K1 72EHS36	3600	5.7

VARIABLE SPEED APPLICATIONS				
Shaft type*	K Series - Hand Start		Variable Speed - Fuel Stop	
	Engine Model	Product code	rpm	kW
2	K1 64	K1 64HS30VS	3000	3.7
		K1 64HS36VS	3600	4.0
2A	K1 72	K1 72HS30VS	3000	5.7
		K1 72HS36VS	3600	6.3

K SERIES: K164 & K172 ENGINES TECHNICAL DATA SHEET

Shaft type*	K Series - Electric Start		Variable Speed - Fuel Stop	
	Engine Model	Product code	rpm	kW
2	K1 64	K1 64ES30VS	3000	3.7
		K1 64ES36VS	3600	4.0
2A	K1 72	K1 72ES30VS	3000	5.7
		K1 72ES36VS	3600	6.3

Shaft type*	K Series - Hand & Electric Start		Variable Speed - Fuel Stop	
	Engine Model	Product code	rpm	kW
2	K1 64	K1 64EHS30VS	3000	3.7
		K1 64EHS36VS	3600	4.0
2A	K1 72	K1 72EHS30VS	3000	5.7
		K1 72EHS36VS	3600	6.3

VARIABLE SPEED APPLICATIONS - PUMP SETS

Shaft type*	K Series - Hand Start		Variable Speed - Fuel Stop	
	Engine Model	Product code	rpm	kW
3	K1 64	K1 64PHS36VS	3600	4.0
5	K1 64	K1 64P75HS36VS	3600	4.0
3A	K1 72	K1 72PHS36VS	3600	6.3

Shaft type*	K Series - Electric Start		Variable Speed - Fuel Stop	
	Engine Model	Product code	rpm	kW
3	K1 64	K1 64PES36VS	3600	4.0
5	K1 64	K1 64P75ES36VS	3600	4.0
3A	K1 72	K1 72PES36VS	3600	6.3

Shaft type*	K Series - Hand & Electric Start		Variable Speed - Fuel Stop	
	Engine Model	Product code	rpm	kW
3	K1 64	K1 64PEHS36VS	3600	4.0
5	K1 64	K1 64P75EHS36VS	3600	4.0
3A	K1 72	K1 72PEHS36VS	3600	6.3

VARIABLE SPEED APPLICATIONS - CAMSHAFT PTO (½ SPEED DRIVE)

Shaft type*	K Series - Hand Start		Variable Speed - Fuel Stop Power	
	Engine Model	Product code	rpm	kW
4	K1 64	K1 64CHS30VS	1500	3.7
		K1 64CHS36VS	1800	4.0
4A	K1 72	K1 72CHS30VS	1500	5.7
		K1 72CHS36VS	1800	6.3

* For shaft and flange dimensions see pages 6-7

POWER TAKE OFF DIMENSIONS - K1 64

Crankshaft PTO

Generator Shaft - Type 1

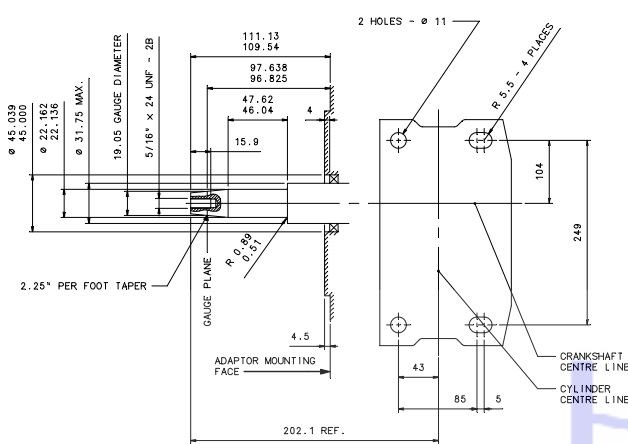

Crankshaft PTO

Parallel Shaft - Type 2

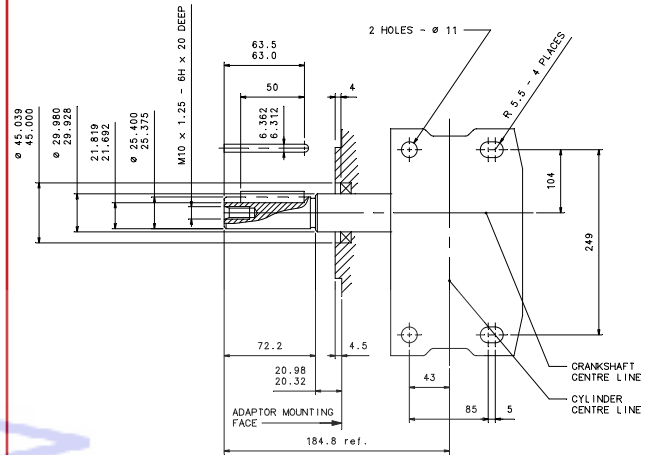

Crankshaft PTO

Pump Shaft - Type 3

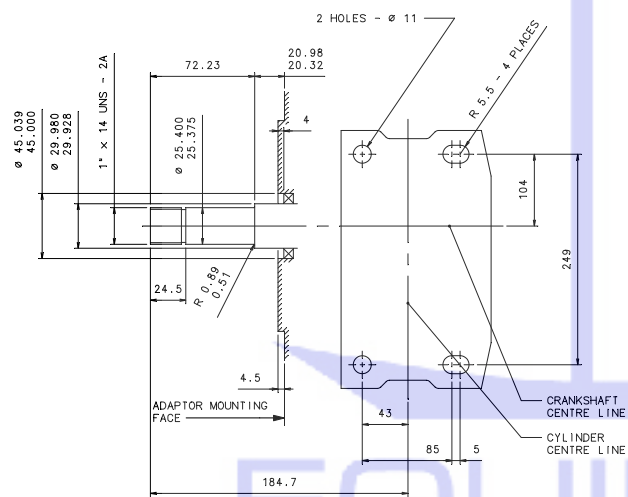

Camshaft PTO (1/2 speed drive)

Parallel Shaft - Type 4

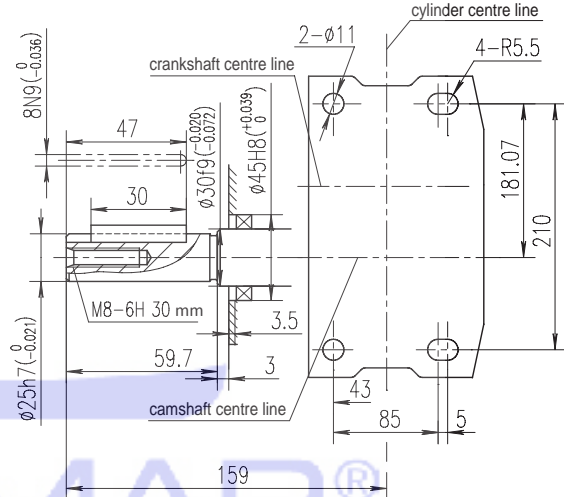

Crankshaft PTO

Pump Shaft - Type 5

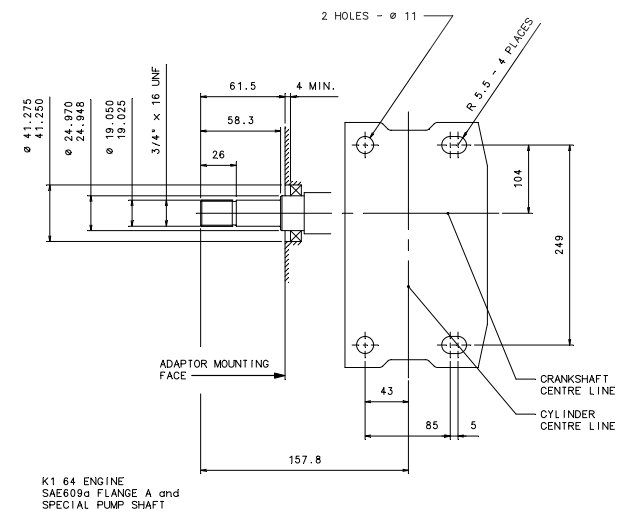

Power Take Off Flange Dimensions - K1 64

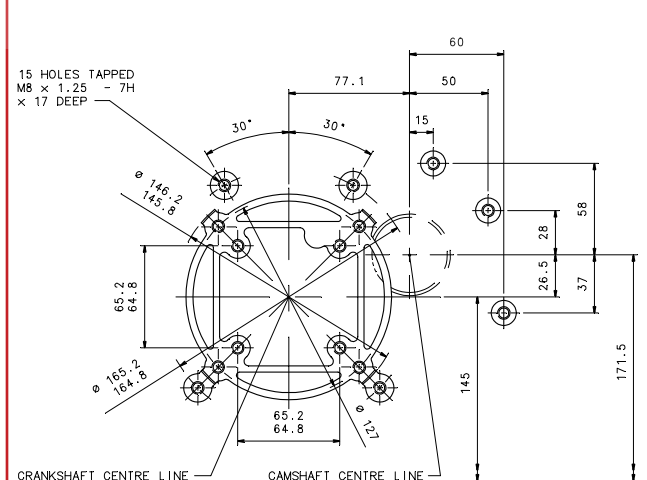

K1 64 ENGINE
SAE609a FLANGE A and
SPECIAL PUMP SHAFT

POWER TAKE OFF DIMENSIONS - K1 72

Crankshaft PTO
Generator Shaft - Type 1A

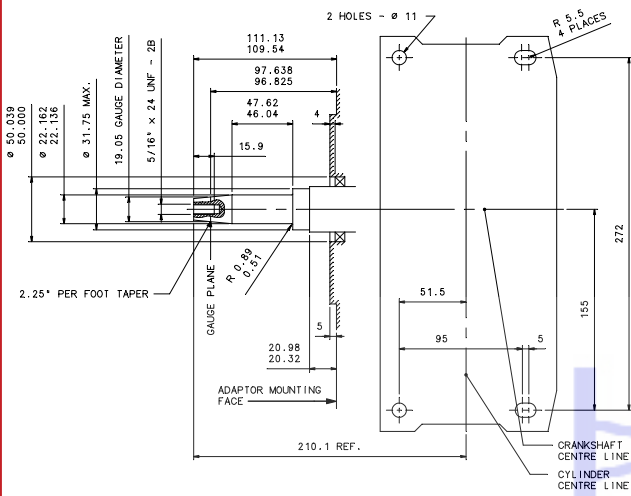

Crankshaft PTO
Parallel Shaft - Type 2A

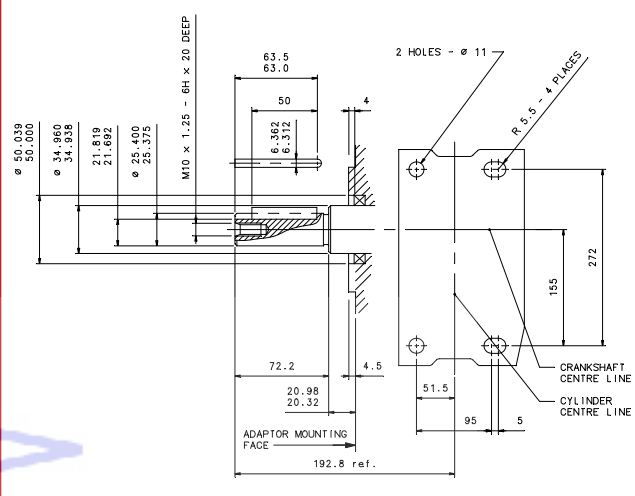

Crankshaft PTO
Pump Shaft - Type 3A

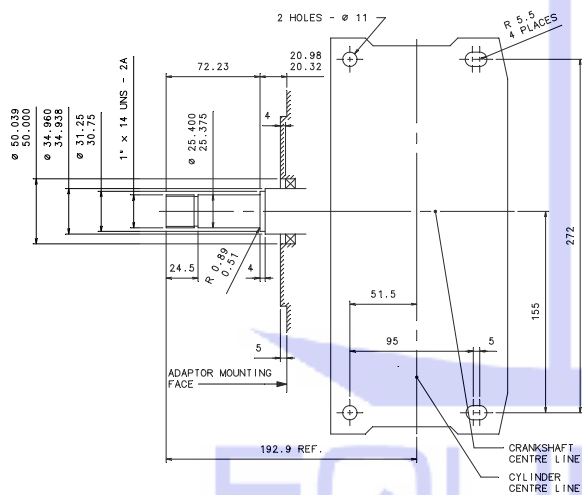

Camshaft PTO (1/2 speed drive)
Parallel Shaft - Type 4A

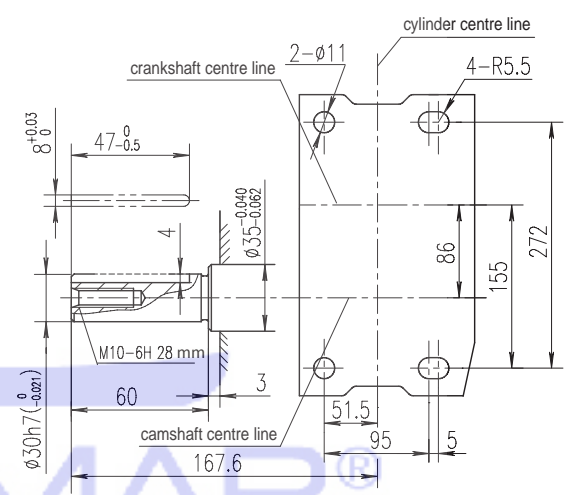

Power Take Off Flange Dimensions - K1 72

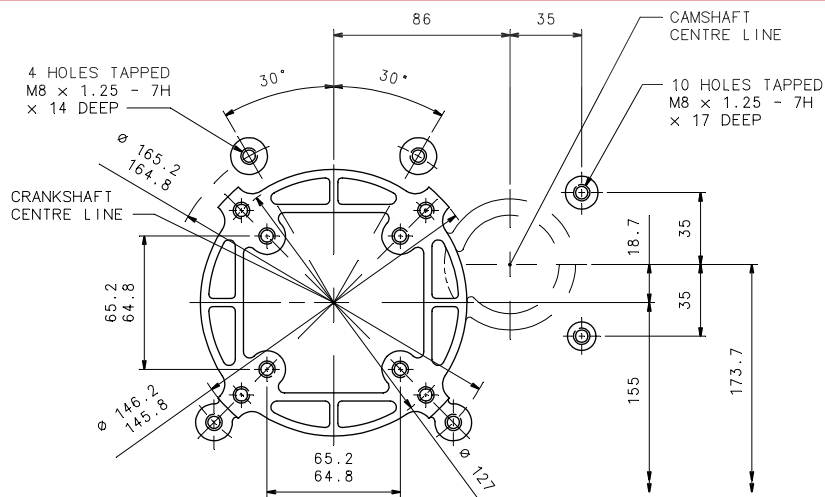

APPROXIMATE DIMENSIONS AND WEIGHT

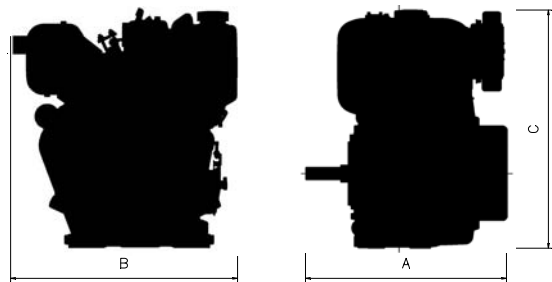

		K1 64	K1 72
Dry weight	kg	33	47
	lb	72.6	103.4
Length (A)	mm	385	420
	in	15.16	16.54
Width (B)	mm	420	440
	in	16.54	17.32
Height (C)	mm	450	495
	in	17.72	19.49

RATING DEFINITIONS TO ISO 3046

ISO Standard Conditions

Barometric pressure 100 kPa

Relative humidity 30%

Ambient temperature at air inlet manifold 25°C

1. Fixed speed power: continuous power (ICN)

The power in kW which the engine is capable of delivering continuously at the stated crankshaft speed, under ISO standard conditions, measured at the flywheel without power-absorbing accessories, provided that the engine is overhauled and maintained in good operating condition and that fuel to BS EN 590 Class A1 or A2, and lubricating oils to the correct performance specification and viscosity classification as recommended by Lister Petter Limited, are used.

2. Fixed speed power: overload power (ICXN)

The maximum power in kW which the engine is capable of delivering intermittently at the stated crankshaft speed for a period not exceeding one hour in any period of twelve hours' continuous running, immediately after working at the continuous power, under

ISO standard conditions and with the provisions specified in (1) above.

3. Variable speed: fuel stop power, continuous power (IFN)

The maximum power in kW which an engine is capable of delivering continuously at stated crankshaft speed, under ISO standard conditions and with the provisions specified in (1) above, with the fuel limited so that the fuel stop power cannot be exceeded.

4. Variable speed: fuel stop power, intermittent power (IOFN)

The maximum power in kW which an engine is capable of delivering intermittently at the stated crankshaft speed, for a period not exceeding one hour in any period of twelve hours' continuous running, with the fuel limited so that the fuel stop power cannot be exceeded, immediately after running at the rating in (3) above, under ISO standard conditions and with the provisions specified in (1) above.

5. De-rating

For non-standard site conditions, reference should be made to relevant BS, ISO and DIN standards.



UK

LISTER PETTER LIMITED

Long Street, Dursley, Gloucestershire, GL11 4HS, England

TEL: +44 (0)1453 544141; FAX: +44 (0)1453 546732

E-mail: sales@lister-petter.co.uk

www.lister-petter.co.uk

UAE

LISTER PETTER FZE

Dubai Silicon Oasis Headquarters,

PO Box 341077, Dubai, UAE

TEL: +971 4 372 4331; FAX: +971 4 372 4318

E-mail: sales@listerpettergroup.com

www.lister-petter.co.uk

DISTRIBUTOR'S ADDRESS

Lister Petter have made efforts to ensure that the information in this data sheet is accurate but reserve the right to amend specifications and information without notice and without obligation or liability.